

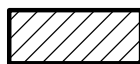

7-F-22-HZ
APPLICATION FOR CERTIFICATE OF APPROPRIATENESS



243 Deaderick Ave. 37921
Mechanicsville H

Original Print Date: 7/6/2022
 Knoxville/Knox County Planning -- Historic Zoning Commission

Petitioner: Bryan Hill

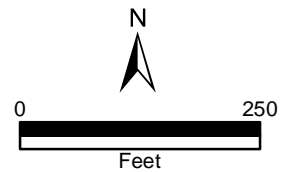

Meeting: 7/21/2022

Applicant: Bryan Hill

Owner: Bryan Hill

Property Information

Location: 243 Deaderick Ave.

Parcel ID 94 F K 025

District: Mechanicsville H

Zoning: RN-2 (Single-Family Residential Neighborhood)

Description: Queen Anne with Eastlake and Tudor influence, c. 1888

Rosecrest, designed by Baumann and Baumann. Two-and-one-half-story frame residence, with a hipped roof with lower cross gables, clad in slate. Exterior clad in wood lap siding and house rests on a brick foundation. House features imbricated shingles in gable and applied half-timbering with central carved panel in porch gable. Double-hung two-over-one and multi-light windows, with additional stained glass windows. Two-story front porch with turned wood columns. Multiple interior brick chimneys.

Description of Work

Level I/II Routine Repair, Construction of Addition or Outbuilding

Exterior rehab elements: repair/replacement in-kind to window trim on east and north elevations. Replacement in-kind to rotten porch boards. Replacement in-kind to exterior wood trim elements.

New secondary structure: new 8' by 12' storage shed on the rear right (north) corner of the property. Shed will be set 5' from interior and rear property lines. Shed features a side-gable roof, clad in asphalt shingles, and an exterior of flush panel siding. The application includes two options for proposed shed; the first option features paired carriage-style doors topped by transom windows and a single window topped by a transom. The second option includes a single carriage-style door flanked by two windows on the side elevation and paired carriage-style doors on the south elevation.

Applicable Design Guidelines

Mechanicsville Design Guidelines, adopted by the Knoxville City Council on September 20, 2011.

U. Rules for Secondary Structures

1. The design of outbuildings, such as garages, shall acknowledge and suggest the function of original outbuildings that would have been located in the neighborhood.
2. The design of features like garage doors that face the street must mimic carriage house doors from an era consistent with the primary building on the lot.
3. Garages and outbuildings must be located behind the primary building at the rear of the lot.
4. Design characteristics and materials used in constructing new outbuildings or accessory buildings must be selected from this list: a roof pitch consistent with the primary building on the lot; overhanging eaves; exposed rafter tails; wood windows; wood lap siding with a four inch lap; board and batten; concrete siding hung to emulate four inch lap siding or used as board in board and batten; masonry, but not exposed concrete block or split-face

Comments

N/A

Staff Findings

1. 243 Deaderick Ave is a contributing resource to the Mechanicsville National Register Historic District and local overlay.
 2. The proposed exterior rehabilitation work, including replacement in-kind to rotted exterior window sills, patching-in of wood lap siding in deteriorated areas, and replacement of exterior wood trim, meets the design guidelines.
 3. The proposed secondary structure is small in size, and will be placed at the rear right corner of the property.
 4. Guidelines recommend that outbuildings' design suggest the function of original outbuildings that would have been located in the neighborhood. The applicant has provided an 1890 Sanborn map showing a similarly-sized, single-story, wood frame shed on the rear left corner of the property.
 5. The primary structure on the property is extremely detailed in design and materials. The proposed shed features carriage-style doors, a simple side-gable roof, and overhanging eaves. Some of the design characteristics listed in the guidelines would not necessarily be compatible with a high-style Queen Anne house, such as the exposed rafter tails. The applicant should incorporate one or two additional characteristics from the guidelines, such as increasing the roof pitch or utilizing board-and-batten siding instead of the flush panel siding initially proposed. If possible, one-over-one windows would be preferable to the false muntins included in the application packet.
-

Staff Recommendation

Staff recommends approval of the work as proposed, subject to the following condition: applicant should incorporate 1-2 additional "design characteristics" listed in the guidelines to further align the shed with the primary structure, with approval by staff.



DESIGN REVIEW REQUEST

- DOWNTOWN DESIGN (DK)
- HISTORIC ZONING (H)
- INFILL HOUSING (IH)

Bryan Hill

Applicant

7/5/22

7/21/22

7-F-22-HZ

Date Filed

Meeting Date (if applicable)

File Number(s)

CORRESPONDENCE

All correspondence related to this application should be directed to the approved contact listed below.

- Owner
- Contractor
- Engineer
- Architect/Landscape Architect

Bryan Hill

Community Development Partners LLC

Name

Company

243 Deaderick Avenue

Knoxville

TN

37921

Address

City

State

Zip

(540) 250-7157

hillguy86@gmail.com

Phone

Email

CURRENT PROPERTY INFO

243 Deaderick Avenue

(540) 250-7157

Owner Name (if different from applicant)

Owner Address

Owner Phone

243 Deaderick Avenue

094FK025

Property Address

Parcel ID

Mechanicsville

RN-2; H

Neighborhood

Zoning

AUTHORIZATION

Lindsay Crockett

Lindsay Crockett

7.5.22

Staff Signature

Please Print

Date

Bryan Hill

Digitally signed by Bryan Hill
Date: 2022.07.05 12:24:33 -04'00'

Bryan Hill

7/5/22

Applicant Signature

Please Print

Date

REQUEST

DOWNTOWN DESIGN

Level 1:

- Signs Alteration of an existing building/structure

Level 2:

- Addition to an existing building/structure

Level 3:

- Construction of new building/structure Site design, parking, plazas, landscape

See required Downtown Design attachment for more details.

Brief description of work: _____

HISTORIC ZONING

Level 1:

- Signs Routine repair of siding, windows, roof, or other features, in-kind; Installation of gutters, storm windows/doors

Level 2:

- Major repair, removal, or replacement of architectural elements or materials Additions and accessory structures

Level 3:

- Construction of a new primary building

Level 4:

- Relocation of a contributing structure Demolition of a contributing structure

See required Historic Zoning attachment for more details.

Brief description of work: Small 8'x12' shed installed rear of house near the northeast property lines. Routine repair and replacement of siding at rear of house where deteriorating. Repair/replacement of window frames where deteriorating along eastern and northern faces of house. Routine repairs to deteriorating front porch floor boards. Replacement of rotted exterior baseboard trim. All wood to be replaced and painted similar. Replacement of concrete sidewalk with brick walkway.

INFILL HOUSING

Level 1:

- Driveways, parking pads, access point, garages or similar facilities Subdivisions

Level 2:

- Additions visible from the primary street Changes to porches visible from the primary street

Level 3:

- New primary structure
 Site built Modular Multi-Sectional

See required Infill Housing attachment for more details.

Brief description of work: _____

STAFF USE ONLY

ATTACHMENTS

- Downtown Design Checklist
 Historic Zoning Design Checklist
 Infill Housing Design Checklist

ADDITIONAL REQUIREMENTS

- Property Owners / Option Holders

Level 1: \$50 • **Level 2:** \$100 • **Level 3:** \$250 • **Level 4:** \$500

FEE 1: 100.00	TOTAL: 100.00
FEE 2:	
FEE 3:	

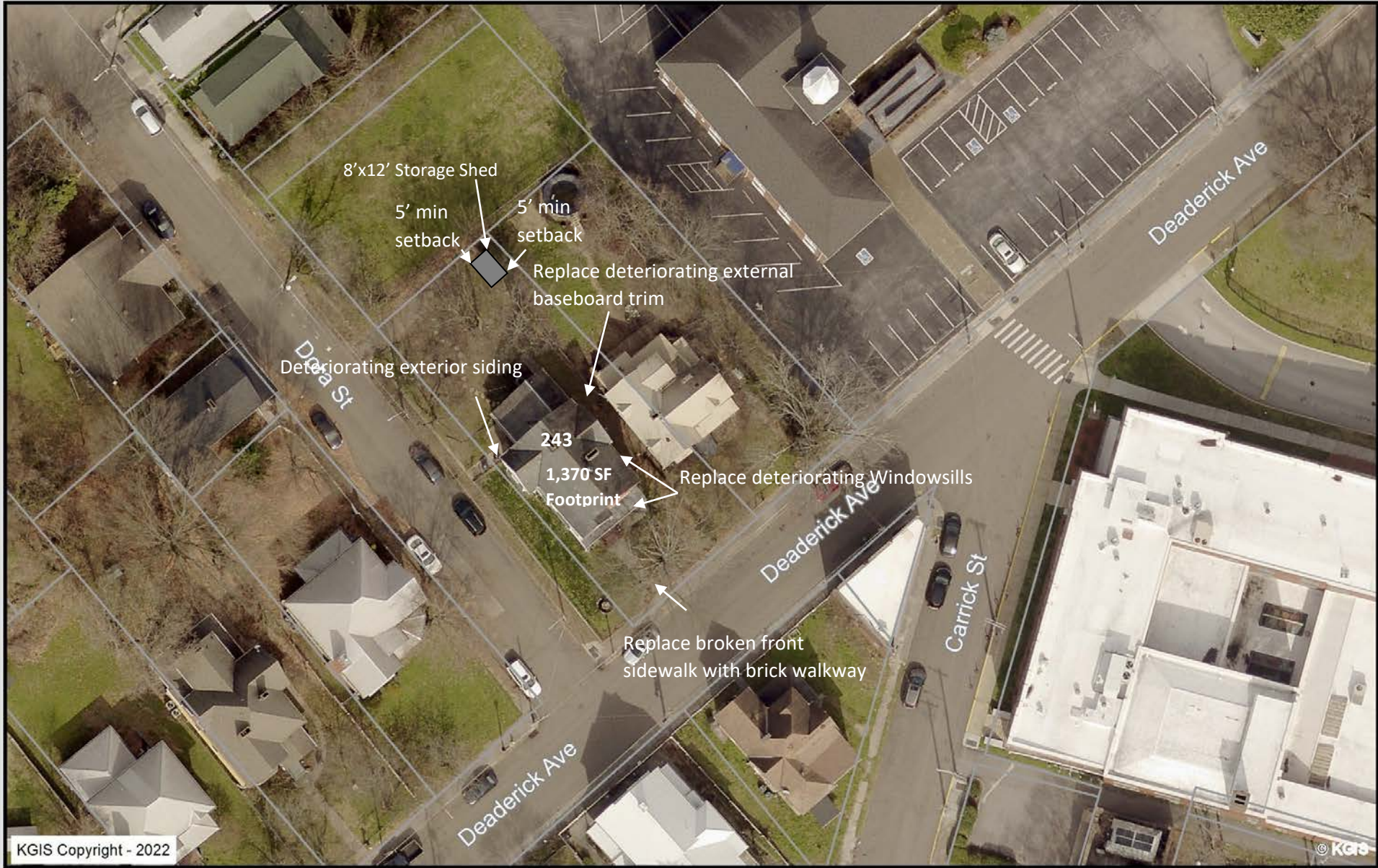

Letter Landscape

Knoxville - Knox County - KUB Geographic Information System



Printed: 7/5/2022 at 10:45:30 AM

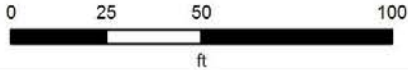

KGIS makes no representation or warranty as to the accuracy of his map and its information nor to its fitness for use. Any user of this map product accepts the same AS IS, WITH ALL FAULTS, and assumes all responsibility for the use thereof, and further covenants and agrees to hold KGIS harmless from any and all damage, loss, or liability arising from any use of this map product.



16986



Call Us First!
DO NOT RETURN TO STORE.

For questions on assembly or for general inquiries, you may contact us in the following ways:

Call customer service: **1-877-743-3400**

AVOID THE WAIT!

visit us online at
help.backyardproducts.com

- Submit a help request
- Answers to frequently asked questions
- Live chat with an agent



Did you enjoy building your shed?

JOIN OUR TEAM
AND MAKE UP TO \$1,500/WEEK*

Call a Recruiter Today! 734-365-7000



Flexible schedule



No selling,
just building



Bonus incentives
available



*based on number of completed installations

(This page intentionally left blank.)

CORONADO 12' x 8' Wide Gable **(365,8 x 243,8 cm)**

KEEP THIS MANUAL FOR FUTURE REFERENCE

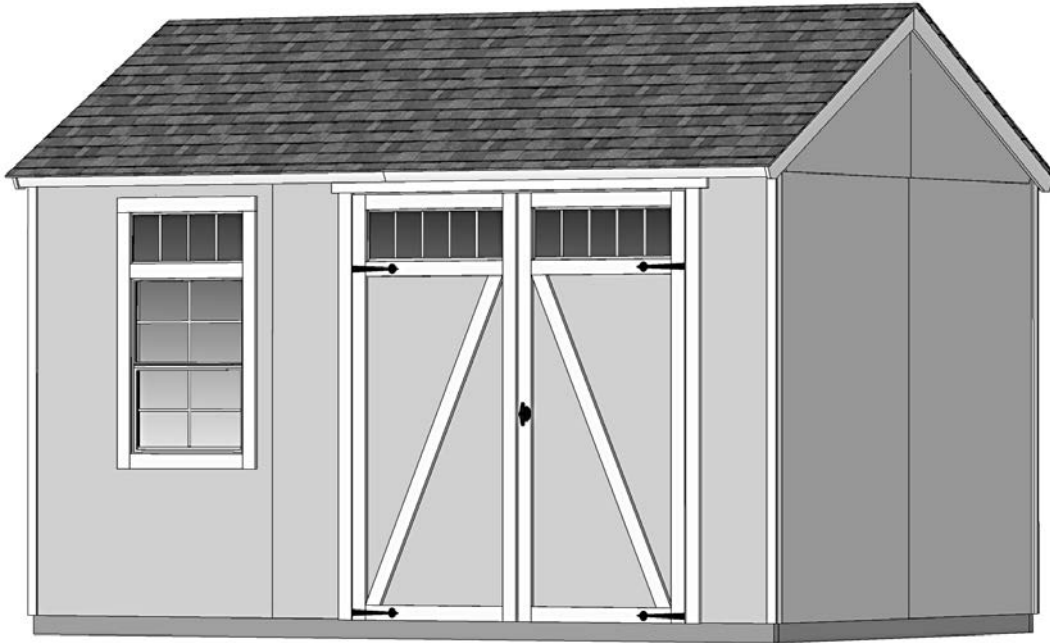

Building 12' x 8' (365,8 x 243,8 cm)

! IMPORTANT! !

READ INSTRUCTIONS THOROUGHLY PRIOR TO BEGINNING ASSEMBLY.

BEFORE YOU BEGIN

• BUILDING RESTRICTIONS AND APPROVALS

Be sure to check local building department and homeowners association for specific restrictions and/ or requirements before building.

• ENGINEERED DRAWINGS

Contact our Customer Service Team if engineered drawings are needed to pull local permits.

• SURFACE PREPARATION

To ensure proper assembly you must build your shed on a level surface.

Recommended methods and materials to level your shed are listed on page 9.

• CHECK ALL PARTS

Inventory all parts listed on pages 3-5.

• ADDITIONAL MATERIALS

You will need additional materials to complete your shed. See page 6 for required and optional materials and quantities.



*****CONTACT OUR CUSTOMER SERVICE TEAM
IF ANY PARTS ARE MISSING OR DAMAGED*****



- Order form and warranty at back of manual -

Call: 1-877-743-3400 email: customerservice@backyardproductsllc.com

TOOLS

Required

Phillips Screwdriver 

Drill / Driver
 3/8" Drill Bit
 #2 Philips Drive Bit

Hammer 

Pencil 

Tape Measure 

Square 

Level 

Chalk Line 

Utility Knife
 Shingle Blades 

Caulk Gun 

Ladder 

Paint Tools 

Optional

Tool Belt/
Nail Pouch 

Safety Glasses 

Nail Gun
 • Gun Nails 

Gloves 

Clamps 

Safety! Always use approved safety glasses during assembly.

HELPFUL REMINDER SYMBOLS

Look for these symbols for helpful reminders throughout this manual.

 = Assistance Required; (2) or more people.

 = Mark part with pencil.

 = Ensure squareness.

 **BEGIN** = Beginning of steps for assembly or installation.

 = Important required step or operation.

 **FINISH** = You have finished the assembly or installation.

 = Helpful assembly hint.

 = Level

ORIENT LUMBER AND TRIM FOR BEST APPEARANCE

Framing lumber is graded for structural strength and not appearance. Exterior trim is graded for one good side.

Always install the material leaving the best edge and best surface visible. Please remember that these blemishes in no way negatively affect the strength or integrity of our product. (See Fig. A, B, C.)

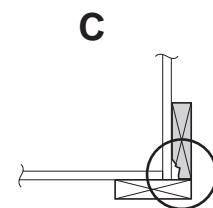
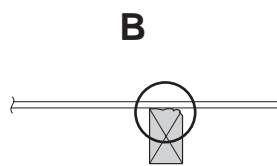
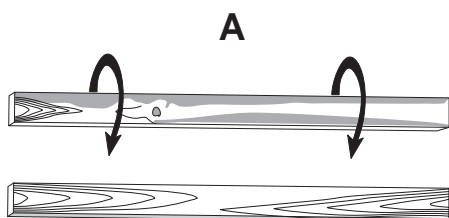

WALL PANEL & DOOR PARTS LIST

NOTE: Panel parts are not stamped with part identification.

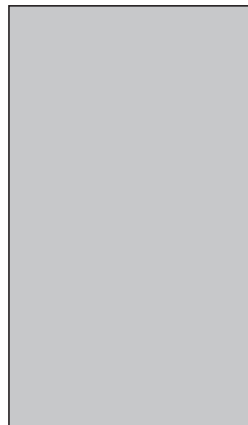
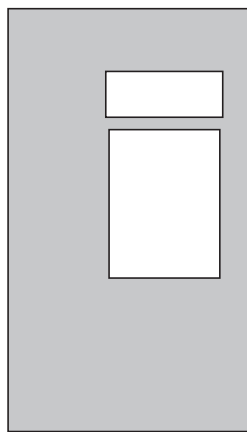
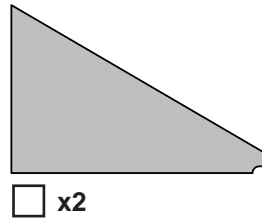
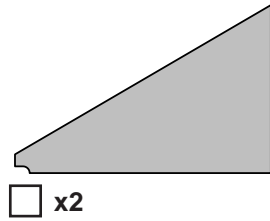

x1
3/8 x 48 x 76"
(1 x 121,9 x 193 cm)

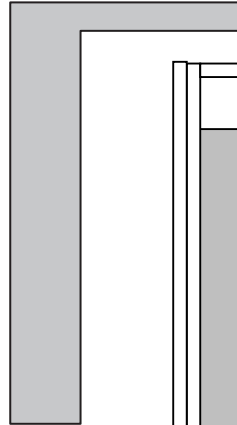

x1
3/8 x 48 x 76"
(1 x 121,9 x 193 cm)

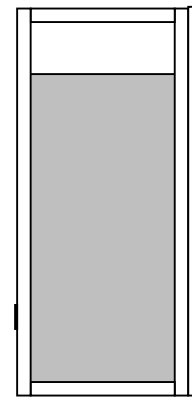
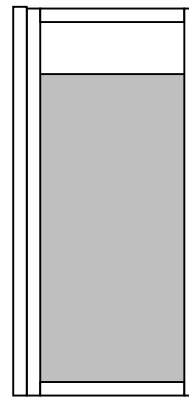
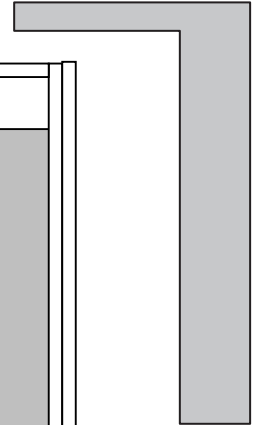

ROOF PANELS

Roof panels are 7/16" (1,1 cm) thick.

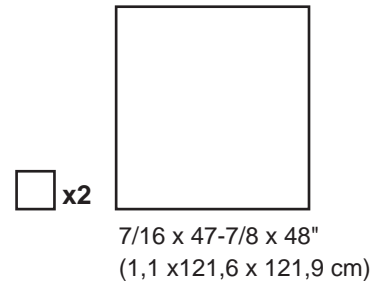
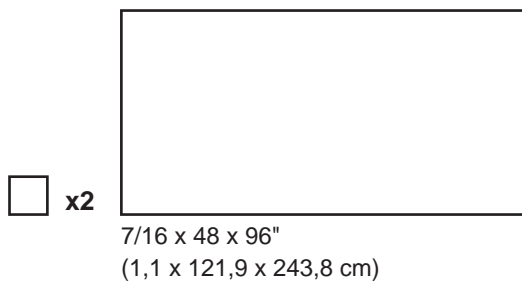
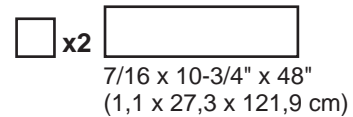
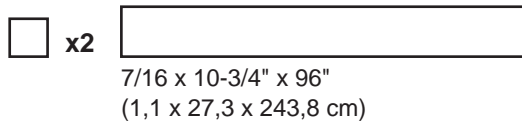

ACCESSORIES & DOOR HARDWARE

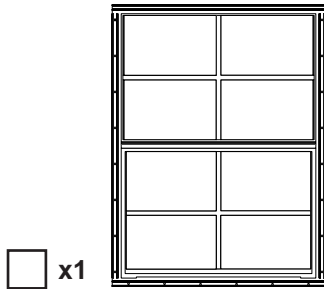
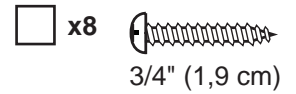
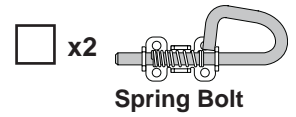
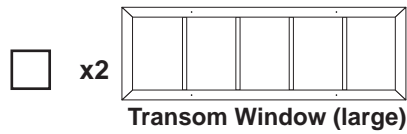
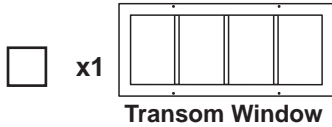

METAL THRESHOLD

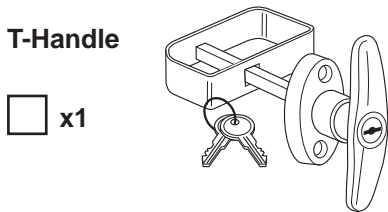
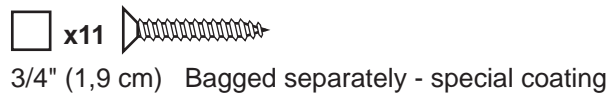
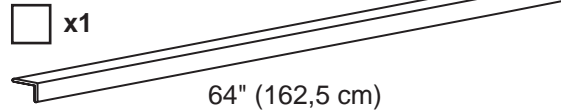

Faux Hinge

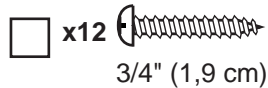
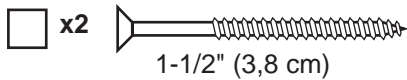
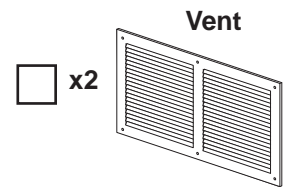
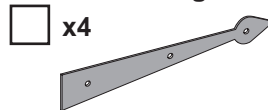

(Not included in base model)

FASTENER/HARDWARE BAG

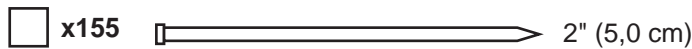
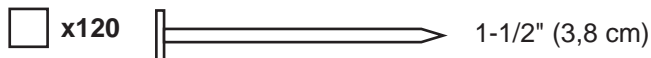

NOTE:

If you are using a nail gun, nails may be used where screws are shown for quicker assembly. Length of nail must match screw length.

NAIL BOXES (Shown Actual Size)

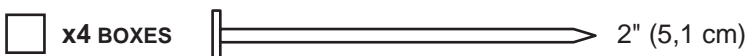
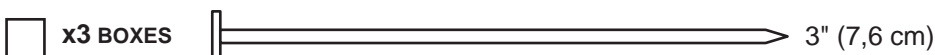

ADDITIONAL MATERIALS

FOUNDATION OR FLOOR MATERIALS

- If your shed came with a separate floor kit, then please use the instructions supplied with that kit to assemble your floor.
- See the FLOOR LEVELING section on page 9 for recommended methods and suggested materials to properly level your floor, as this will vary depending on your specific site.
- If you choose to install your floor on a concrete slab, refer to page 7.
- If you choose to build your own wood floor foundation, refer to page 8.

REINFORCED WOOD FLOOR FRAME (OPTIONAL)

IMPORTANT! Depending on your specific use you may want to construct a heavy duty floor frame by adding additional floor joists (shown below as shaded). Below is a list of additional materials (not included):

- x3** 2 x 4 x 8' (5 x 10 x 243,8 cm) Treated Lumber
Cut to (3) 2 x 4 x 93" (5 x 10 x 236,2 cm)
- x12** ea. 3" (7,6 cm) Hot Dipped Galvanized Nails

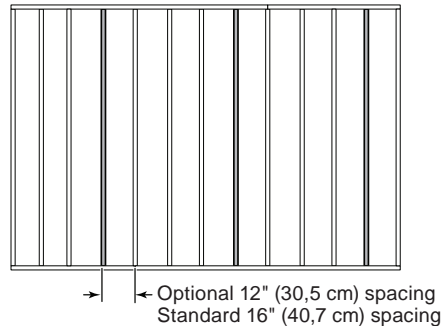

COMPLETING YOUR SHED

You will need these additional materials:

- | | |
|---|--|
| <input type="checkbox"/> 3-TAB SHINGLES6 Bundles | <input type="checkbox"/> 1" GALVANIZED ROOFING NAILS 4 Lbs
For shingles. |
| <input type="checkbox"/> PAINT FOR SIDING2 Gallons
Use 100% acrylic latex exterior paint. (2) coats recommended. | <input type="checkbox"/> PAINT FOR TRIM 1 Quart
Use 100% acrylic latex exterior paint. |
| <input type="checkbox"/> CAULK3 Tubes
Use acrylic latex exterior caulk that is paintable.  | |

You must caulk completely around window frame to validate your warranty. Use a paintable exterior rated caulk.

OPTIONAL MATERIALS

- | | |
|---|--|
| <input type="checkbox"/> DRIP EDGE 50 Feet | <input type="checkbox"/> #15 ROOFING FELT
To cover 147 Sq. Ft. of roof area. |
| | <input type="checkbox"/> 1" GALVANIZED ROOFING NAILS1/4 Lb
For roofing felt. |

REFER TO THE BACK OF THIS MANUAL AND THE MANUFACTURER'S INSTRUCTIONS FOR INSTALLATION OF SHINGLES, DRIP EDGE AND FELT.

CONCRETE FOUNDATION

If you choose to install your kit on a concrete slab refer to the diagram below.

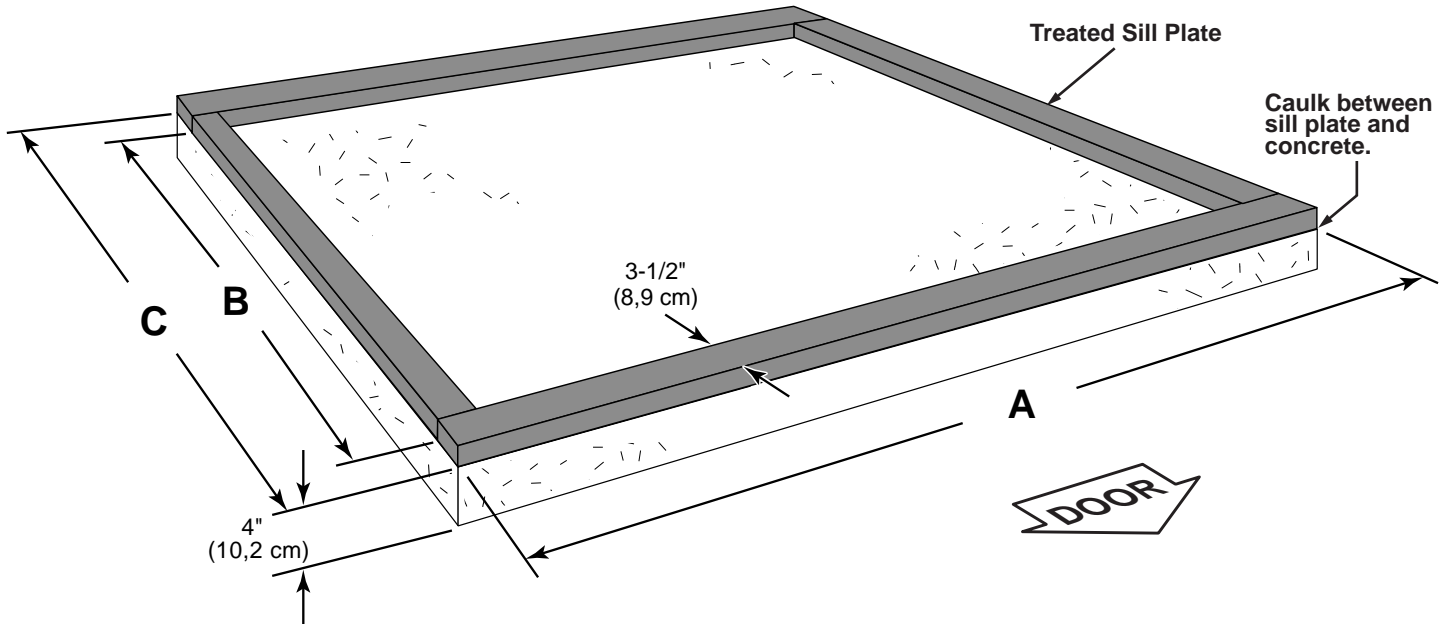

Building Size	Actual Size	A	B	C
12' x 8' (365,8 x 243,8 cm)	144" x 96" (365,8 x 243,8 cm)	144 " (365,8 cm)	89" (226,1 cm)	96" (243,8 cm)

Requires:

- x2 2 x 4 x 12' (5,1 x 10,2 x 365,8 cm) **MUST be treated lumber.**
- x2 2 x 4 x 8' (5,1 x 10,2 x 243,8 cm) **MUST be treated lumber.**
- x1 Caulk

Allow new concrete slabs to cure for at least seven (7) days.

- A treated 2 x 4 (5,1 x 10,2 cm) sill plate is required when installing your shed on concrete.
Hint: Purchase full length treated lumber.
- Use a high quality exterior grade caulk beneath all sill plates.
- Fasten 2 x 4 (5,1 x 10,2 cm) sill plates to slab using approved concrete anchors (**fasteners not included**).
- Check local code for concrete foundation requirements.

NOTES

BUILD YOUR OWN WOOD FLOOR OPTION

(Materials not included.)

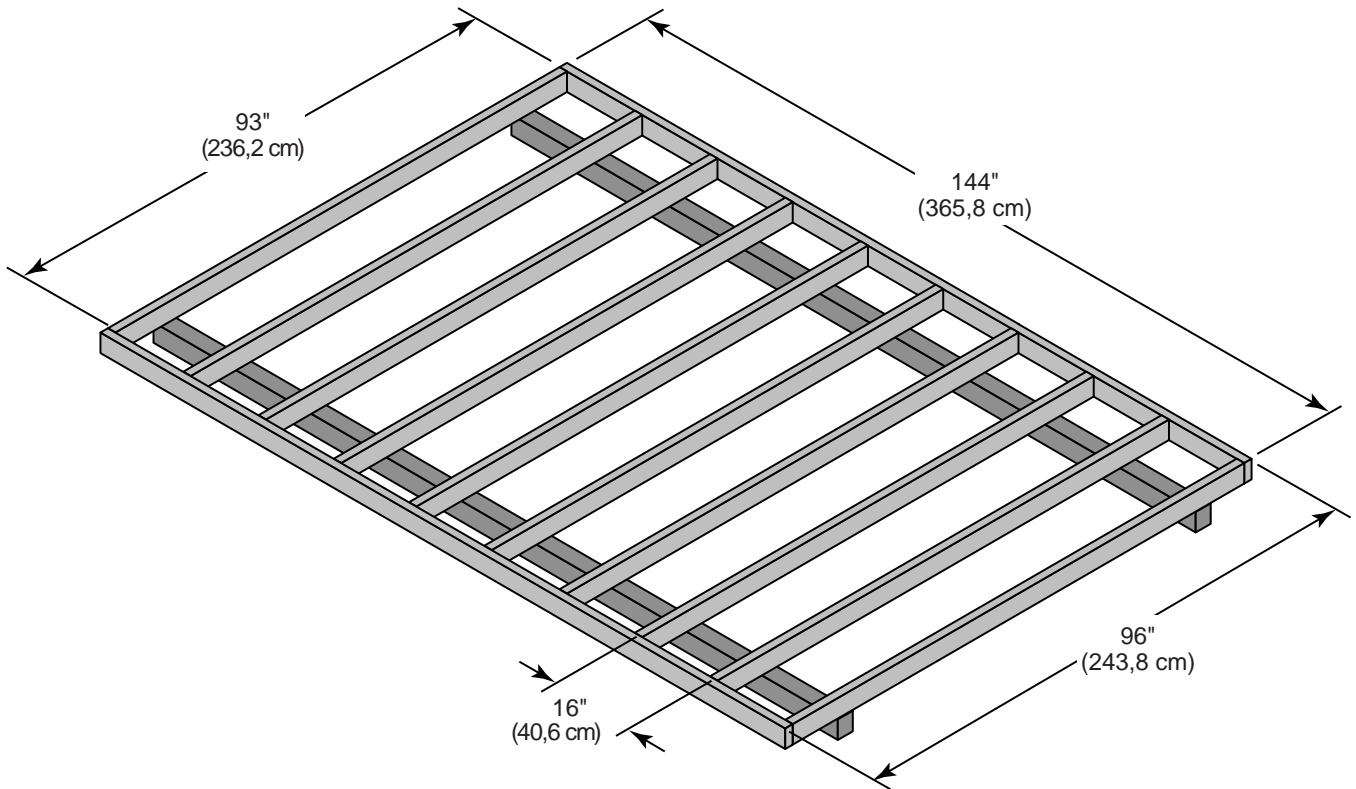

MATERIAL REQUIRED

- x2** 2 x 4 x 12' (5,1 x 10,2 x 365,8 cm) **MUST be treated lumber**
- x10** 2 x 4 x 8' (5,1 x 10,2 x 243,8 cm) **MUST be treated lumber**
- x2** 4 x 4 x 12' (10,2 x 10,2 x 365,8 cm) **MUST be treated lumber**

- x3** 5/8" x 48" x 96" (1,6 x 121,9 x 243,8 cm)

- x1** 2" (5,1 cm) 1 lb. of 2" (5,1 cm) Hot Dipped Galvanized Box-Type Nails

- x40** 3" (7,6 cm) 40 Nails - 3" (7,6 cm) Hot Dipped Galvanized Box-Type Nails

- x40** 3" (7,6 cm) Screws for Frame to 4"x 4"
Minimum 3" screws / exterior grade.

GABLE TRIM

PARTS REQUIRED:

x2 **REL**
19/32 x 3-1/2 x 60-1/8" (1,5 x 8,9 x 152,7 cm)

x2 **RER**
19/32 x 3-1/2 x 60-1/8" (1,5 x 8,9 x 152,7 cm)

x40  2" (5,1 cm)

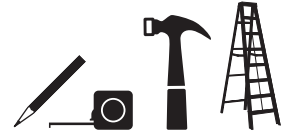

✓ **BEGIN**

- 1 Install **REL** and **RER** primed side out, flush to top of roof panels and flush at peak.
Secure trim to rafter with 2" finishing nails spaced evenly and as the pattern below shows.

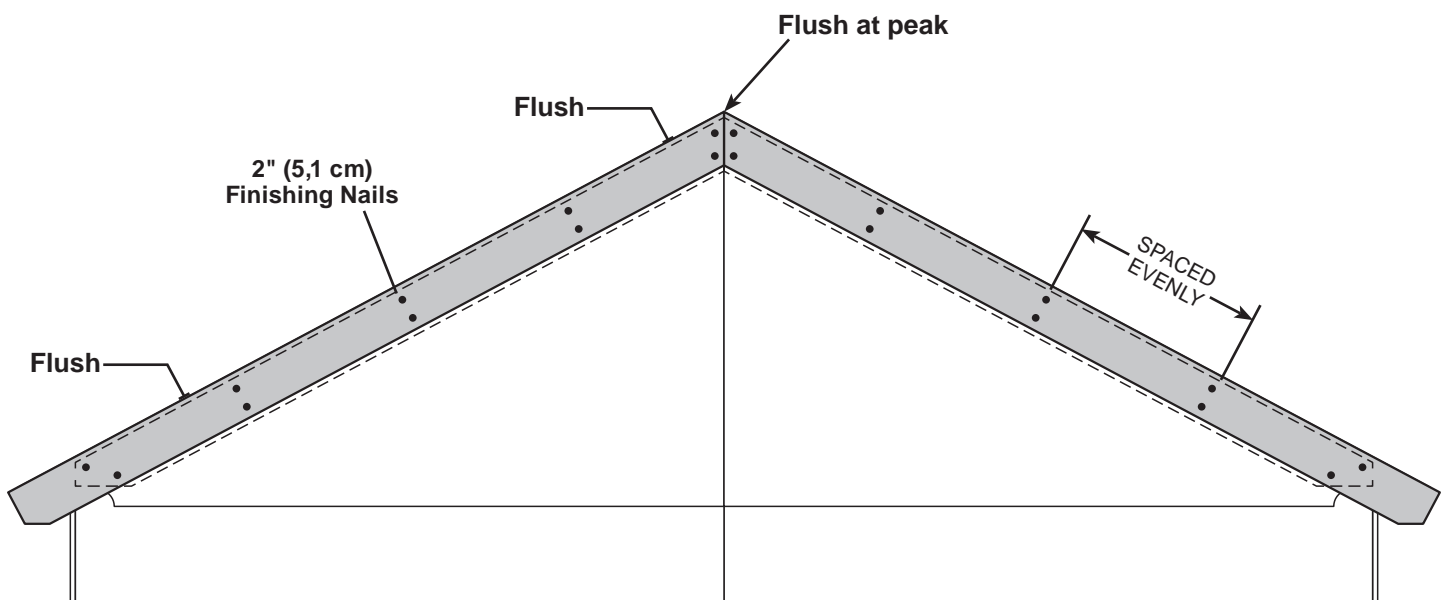

Repeat steps to install **REL** and **RER** on opposite side.



Your gable trim is now installed.

SOFFIT TRIM

PARTS REQUIRED:

x2 **NKA**
2 x 4 x 49-1/2" (5,1 x 10,2 x 125,7 cm)

x2 **TP**
2 x 4 x 96" (5,1 x 10,2 x 243,8 cm)

x78 
1-1/4" (3,2 cm)



✓ **BEGIN**
1

Install parts **TP** and **NKA** flush to bottom of roof overhang and flush to wall panel as shown (**Fig. A**).
Secure with 3" nails in the pattern shown.

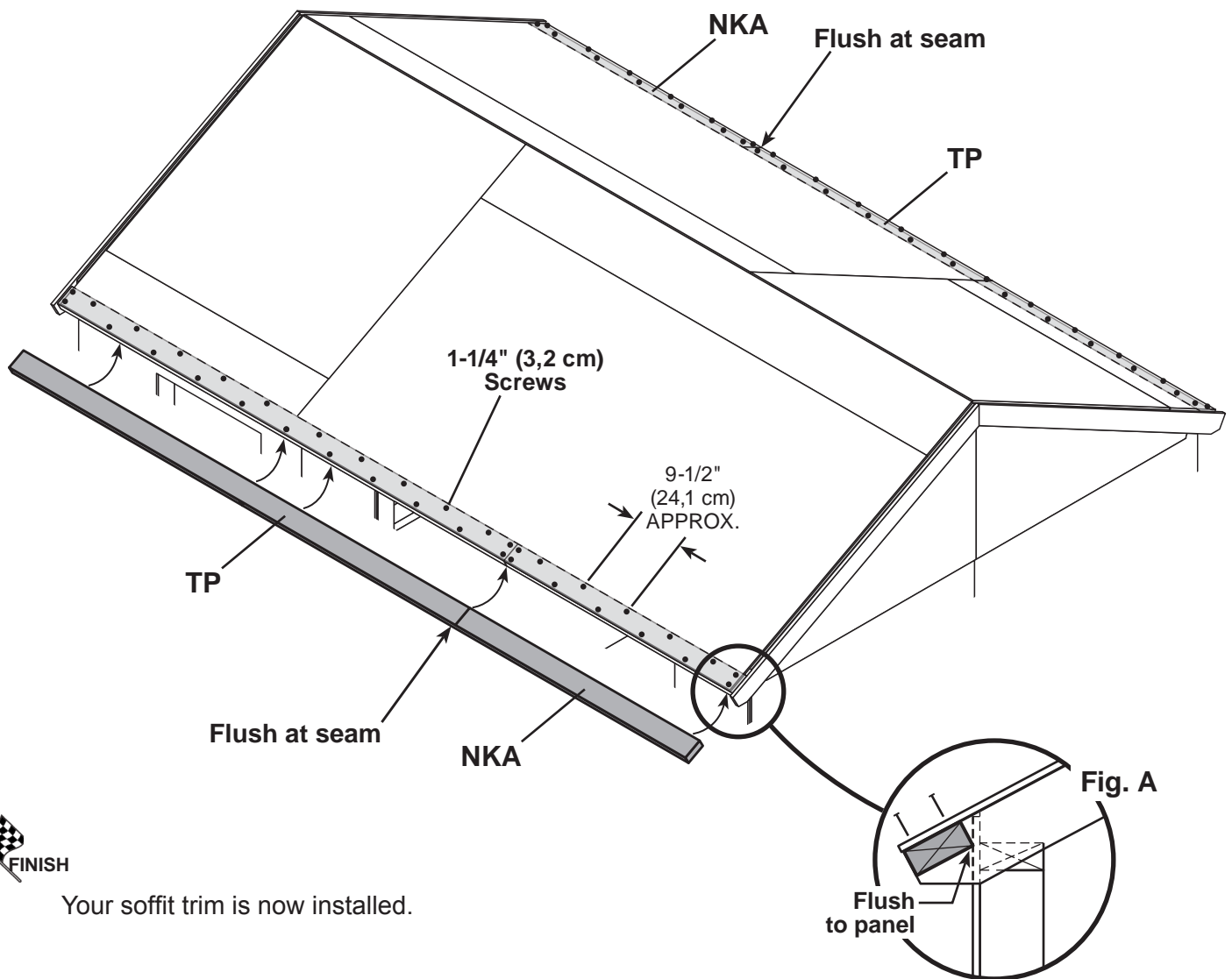

✓ **FINISH**

Your soffit trim is now installed.

EAVE FASCIA

PARTS REQUIRED:

x4 
3/8 x 2-1/2 x 72-3/4" (1,0 x 6,3 x 184,8 cm)

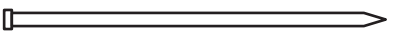
x20 
2" (5,1 cm)



✓ **BEGIN**
1

Install 2-1/2" x 72-3/4" fascia flush at center and flush with top of roof panels (**Fig. A**).
Secure fascia to soffit 2 x 4 overhang with 2" finishing nails.

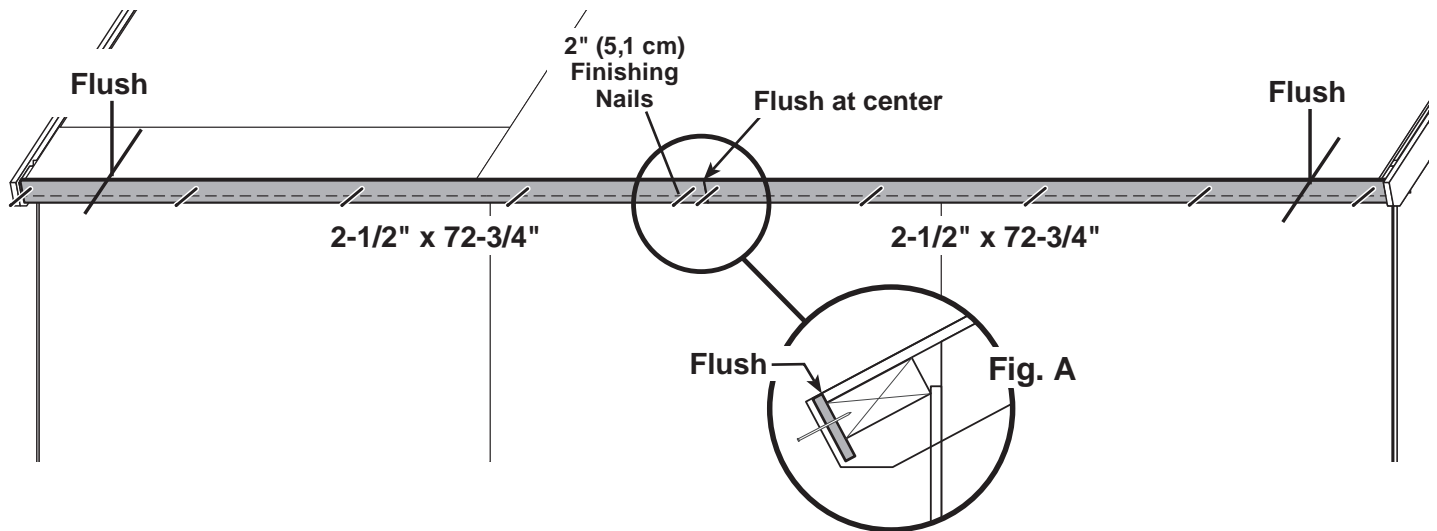

Repeat steps for opposite side of shed.

 **FINISH**

Your eave fascia is now installed.

CORNER TRIM

PARTS REQUIRED:

x8 
 3/8 x 1-3/4 x 75-3/4" (1 x 4,4 x 192,4 cm)

x56 
 2" (5,1 cm)



✓ BEGIN

- 1 Install eave side **75-3/4"** corner trim under eave soffit, **(Fig. A)** and flush to eave wall panel **(Fig. B)**. Secure with 2" finishing nails spaced evenly.
- 2 Install gable side **75-3/4"** corner trim flush along seam of installed trim **(Fig. C)** and flush to gable panel **(Fig. A)**. Secure with 2" finishing nails spaced evenly.

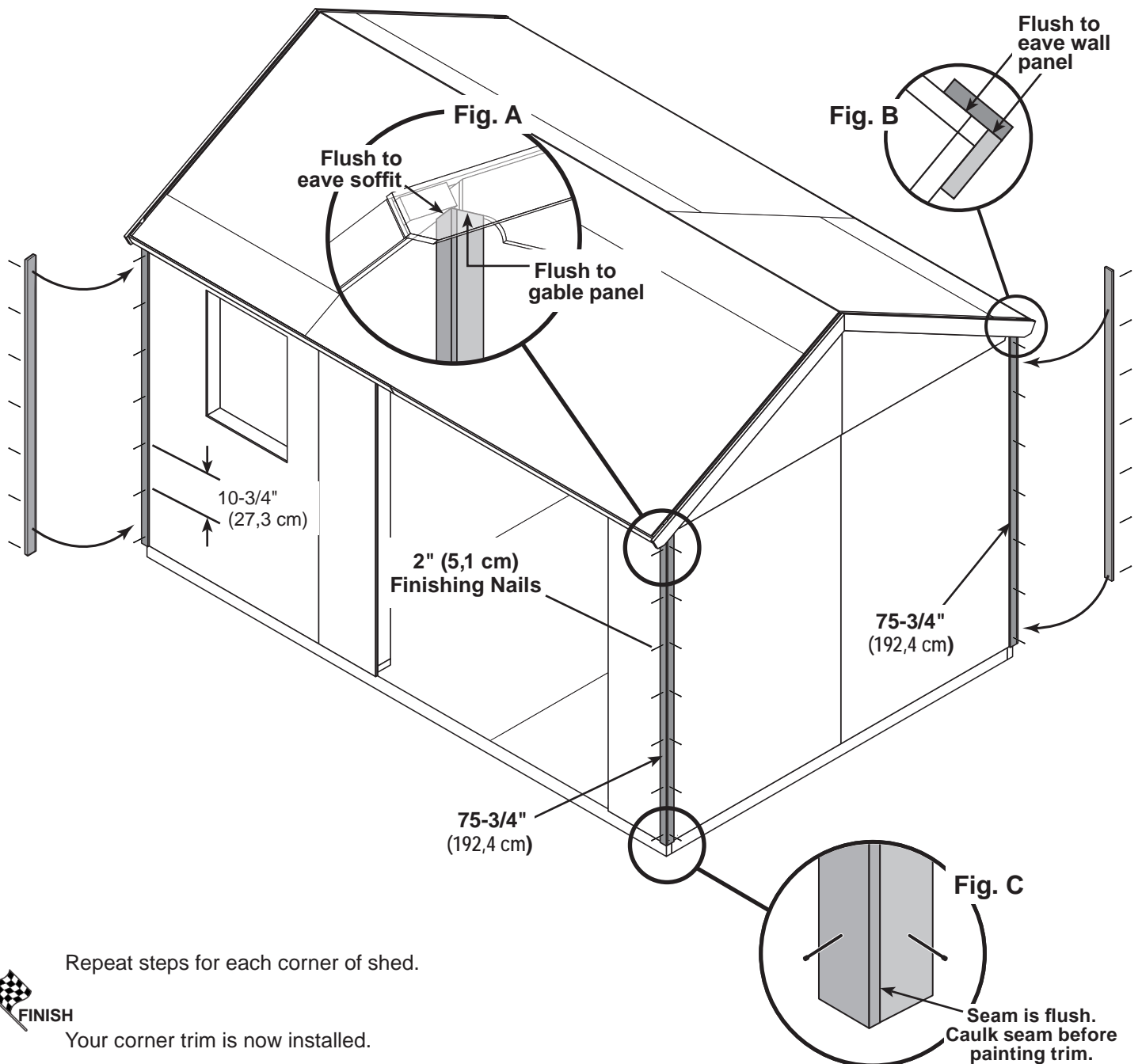

Repeat steps for each corner of shed.



FINISH

Your corner trim is now installed.

HILLSDALE GABLE 8' x 12' (244 x 366 cm)

ACTUAL FLOOR SIZE IS 96 x 144" (243,8 x 365,8 cm)

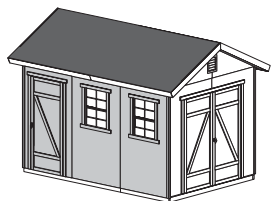
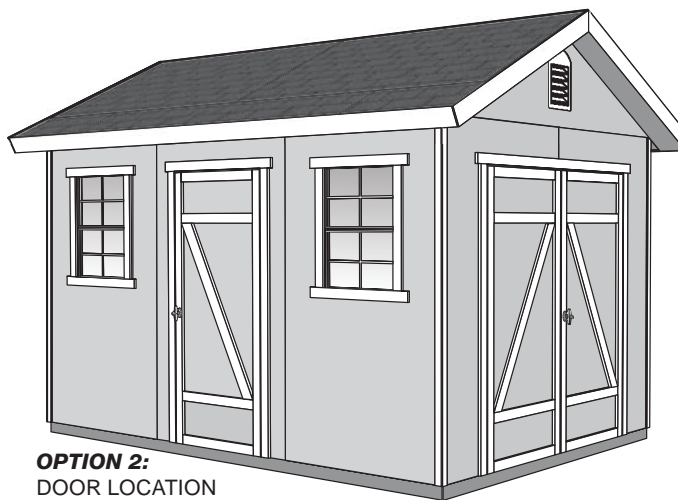
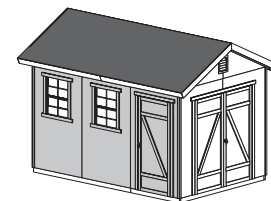
KEEP THIS MANUAL FOR FUTURE REFERENCE**OPTION 1:**
DOOR LOCATION
LEFT SIDE OF EAVE WALL**OPTION 2:**
DOOR LOCATION
CENTERED ON EAVE WALL**OPTION 3:**
DOOR LOCATION
RIGHT SIDE OF EAVE WALL**! IMPORTANT! !****READ INSTRUCTIONS THOROUGHLY PRIOR TO BEGINNING ASSEMBLY.****BEFORE YOU BEGIN****• BUILDING RESTRICTIONS AND APPROVALS**

Be sure to check with local building department and homeowners association for specific restrictions and/ or requirements before building.

• ENGINEERED DRAWINGS

Contact our Customer Service Team if engineered drawings are needed to pull local permits.

• SURFACE PREPARATION

To ensure proper assembly you must build your shed on a level surface. Recommended methods and materials to level your shed are listed on page 9.

• CHECK ALL PARTS

Inventory all parts listed on pages 3 - 5. Contact our Customer Service Team if any parts are missing or damaged.

• ADDITIONAL MATERIALS

You will need additional materials to complete your shed. See page 6 for required and optional materials and quantities.

**- CUSTOMER SERVICE -****Call: 1-800-577-9663 email: customerservice@backyardproductsllc.com**