

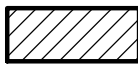

5-H-21-HZ
APPLICATION FOR CERTIFICATE OF APPROPRIATENESS



24 Market Square 37902
Market Square H

Original Print Date: 5/5/2021
 Knoxville/Knox County Planning -- Historic Zoning Commission

Petitioner: James Sherrod Sherrod Signs

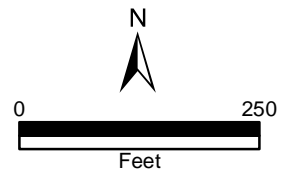



Staff Report

Knoxville Historic Zoning Commission

File Number: 5-H-21-HZ

Meeting: 7/15/2021
Applicant: James Sherrod Sherrod Signs
Owner: Square Properties LLC

Property Information

Location: 24 Market Square **Parcel ID** 94 L E 040
District: Market Square H
Zoning: DK (Downtown Knoxville)
Description: Victorian Vernacular Commercial, c.1880

Two-story brick building with three-bays, arched second-story windows with corbelled arched window hoods with replacement sashes and a corbelled brick cornice. Altered c.1930s storefront.

Description of Work

Level II Installation of Signage

No change to initially proposed placement. New sign to be attached to center of projecting, flat-roof canopy. Currently proposed sign measures 3' tall by 4'-8" wide (13 sq. ft.) overall, featuring a semi-circle section on top of a rectangular base. The sign will be illuminated with green and gold neon tubing, with transformer and associated electrical equipment located within the sign. The sign will be centered on the projecting canopy, below the middle second-story window, located towards the edge of the canopy, perpendicular to the building façade.

Applicable Design Guidelines

Market Square Design Guidelines and Designation Report, adopted by the Knoxville City Council on July 24, 2001.

1. A storefront shall not have more than two signs, a primary and a secondary sign. One of these may be a flush-mounted sign board located below the second story window sills and above the storefront display windows. It should not be more than 2-1/2' high with lettering between 8" and 18" high and covering about 65% of the sign board.
2. A hanging sign can be mounted above the sidewalk, projecting no more than five feet. It could represent the image of a product or use text to identify a tenant and should be 4-6 square feet in area.
4. Signs may be used on awnings, but shall be configured with contrasting letters painted or sewn onto the awnings valance.
5. Signs can be directly or indirectly illuminated. Internally lit signs that respect the dimensions noted above for flush-mounted sign boards can be appropriate. Neon can be appropriate for flush-mounted sign boards and window signs.

Comments

This case was postponed from the May 2021 meeting.

Staff Findings

1. 24 Market Square is a contributing resource to the Market Square National Register Historic District and the local overlay.
2. Signs which directly correspond with the design guidelines are often approved on a staff level in Historic overlays. The proposed sign is larger from the recommended size for a projecting sign (13 sq. ft. vs. the recommended 4-6 sq. ft.), and has a unique placement, centered on the flat-roof canopy. The application was postponed at the May 2021 HZC meeting to allow the applicant to submit a revised proposal which more clearly meets the design guidelines for placement and size of signs.
3. The applicant was not present at the May 2021 meeting. Staff has provided several suggestions for alternate sign placement, including a signboard, a projecting sign on the right-side brick pilaster, or window signs. The applicant has opted to resubmit the same sign in the same location and attend the meeting to further discuss the proposed sign.
4. City sign code (13.6.C.2) states that canopy signs cannot extend above the highest point of the canopy upon which it is attached or two feet, whichever is greater. The sign, as currently proposed, exceeds two feet above the canopy. The applicant has stated their willingness to reduce the sign's size but intends to maintain placement on the awning.
5. Neon is noted in the design guidelines as appropriate for sign boards and window signs. There are several larger-sized neon signs installed on Gay Street, on historic commercial buildings which contribute to the Gay Street Commercial National Register Historic District.

Staff Recommendation

Staff recommends postponement of the review to provide the applicant the opportunity to submit alternate designs which meet the City sign code and the Market Square design guidelines. Pending receipt of a revised sign proposal, the Commission may choose to review and approve a smaller-sized sign on the canopy; or an alternate design provided by the applicant in advance of the meeting.

REQUEST

DOWNTOWN DESIGN

Level 1:

- Signs Alteration of an existing building/structure

Level 2:

- Addition to an existing building/structure

Level 3:

- Construction of new building/structure Site design, parking, plazas, landscape

See required Downtown Design attachment for more details.

Brief description of work: _____

HISTORIC ZONING

Level 1:

- Signs Routine repair of siding, windows, roof, or other features, in-kind; Installation of gutters, storm windows/doors

Level 2:

- Major repair, removal, or replacement of architectural elements or materials Additions and accessory structures

Level 3:

- Construction of a new primary building

Level 4:

- Relocation of a contributing structure Demolition of a contributing structure

See required Historic Zoning attachment for more details.

Brief description of work: _____

INFILL HOUSING

Level 1:

- Driveways, parking pads, access point, garages or similar facilities Subdivisions

Level 2:

- Additions visible from the primary street Changes to porches visible from the primary street

Level 3:

- New primary structure
 Site built Modular Multi-Sectional

See required Infill Housing attachment for more details.

Brief description of work: _____

STAFF USE ONLY

ATTACHMENTS

- Downtown Design Checklist
 Historic Zoning Design Checklist
 Infill Housing Design Checklist

ADDITIONAL REQUIREMENTS

- Property Owners / Option Holders

Level 1: \$50 • **Level 2:** \$100 • **Level 3:** \$250 • **Level 4:** \$500

FEE 1:

FEE 2:

FEE 3:

TOTAL:

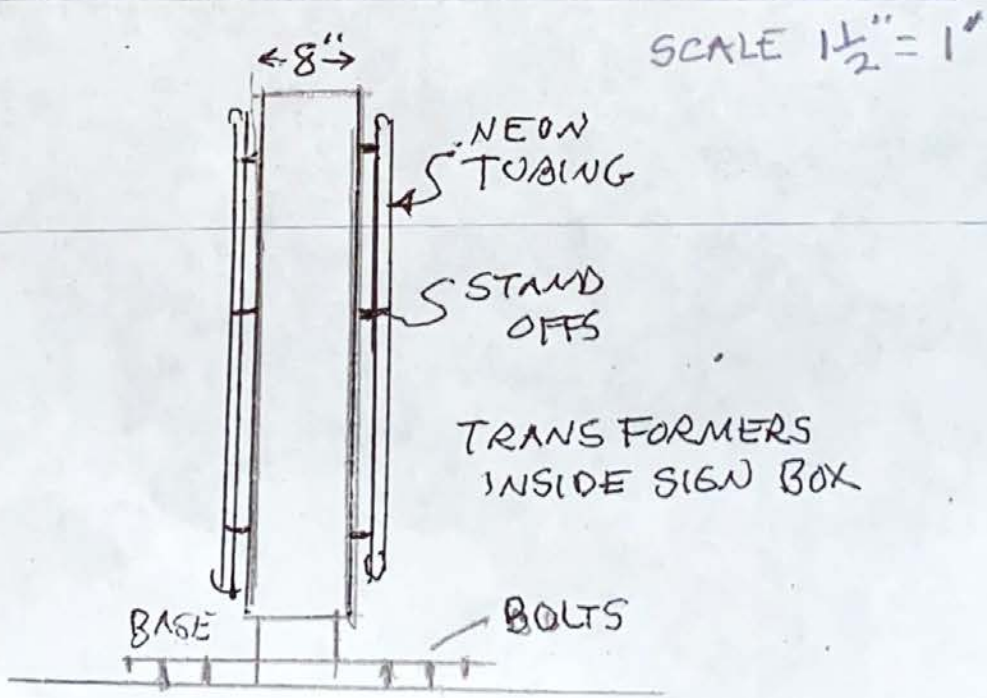
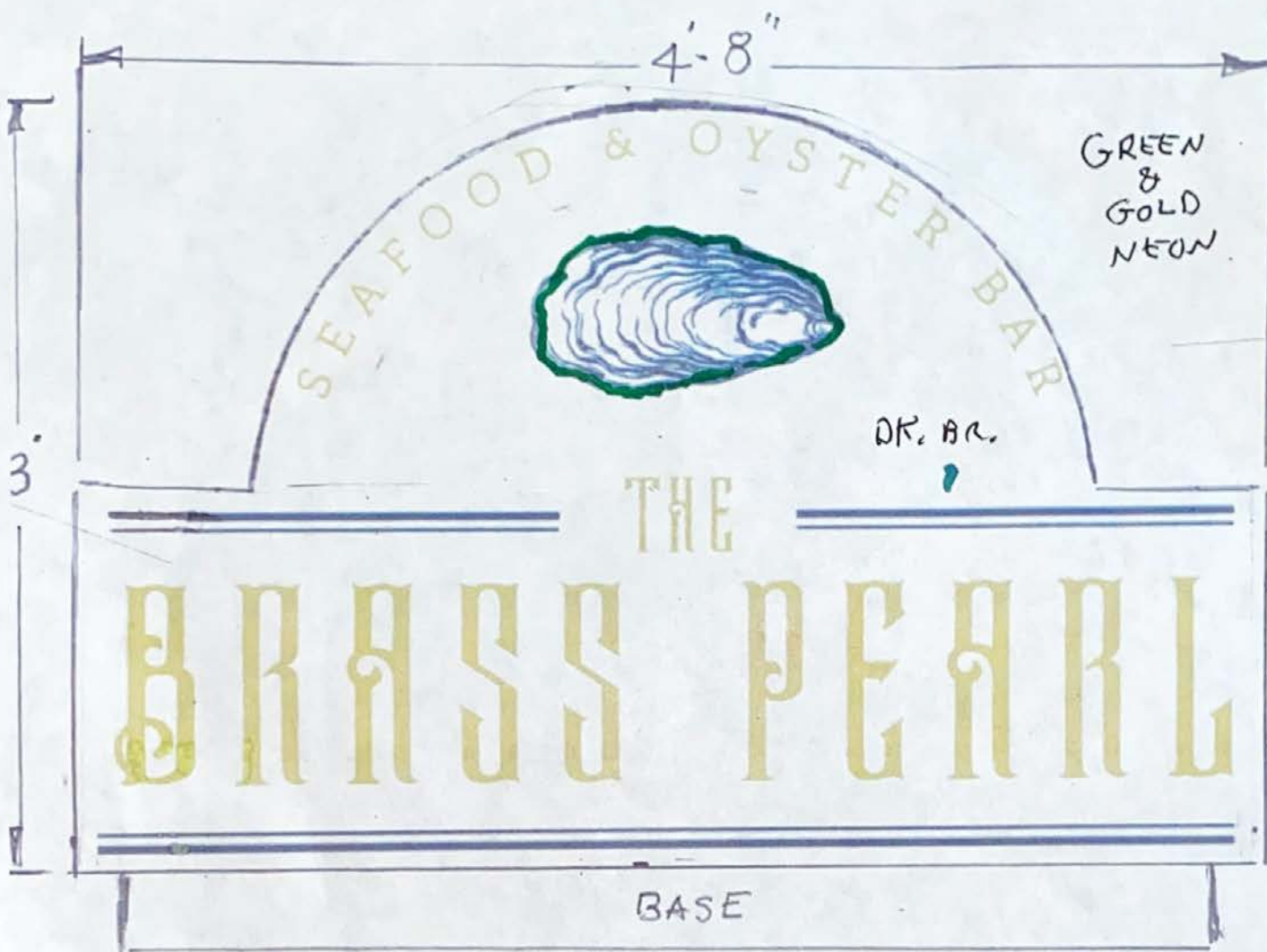

ATT. LINDSEY

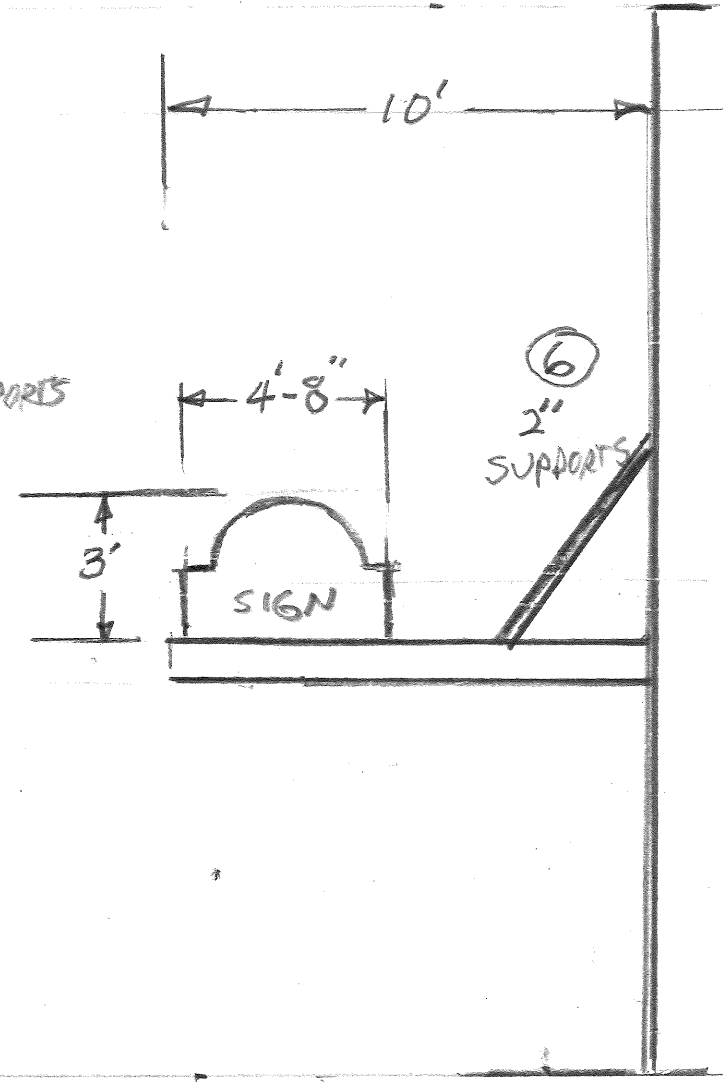
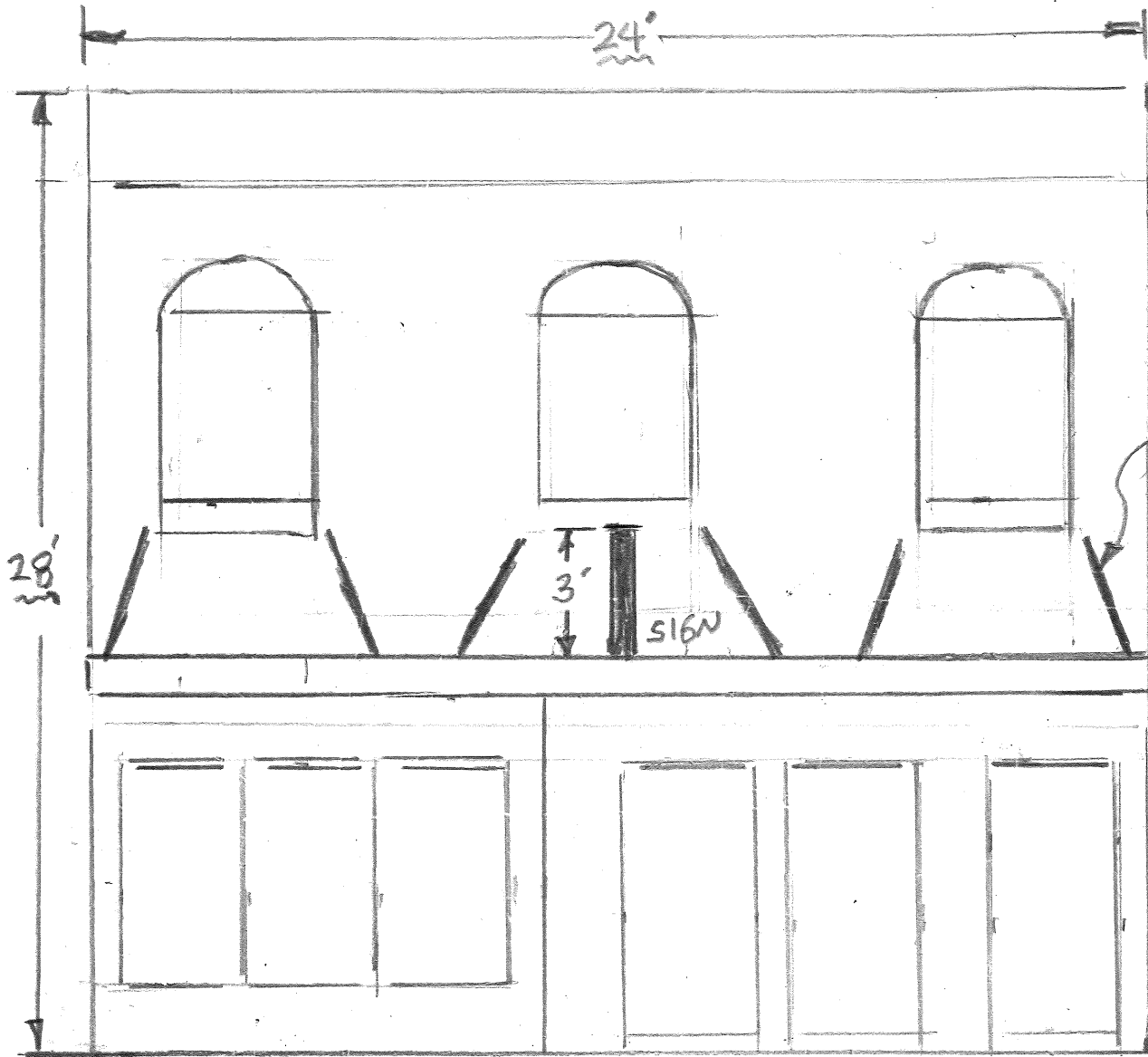

24 MARKET ST.

SCALE $\frac{1}{4}'' = 1'$

JAMES SHERROD
865-963-8398